



MYERS TANKS

Used Oil Storage Tank System - HD (HEAVY DUTY)

UL 142, ULC-S652-1993, ULC/ORD-C142.22-1995, CAN 4/ULC-S630-M84, CSA Standard W47.1-1992

Designed for the Storage of Used Oil

Available in 3 sizes

Applications:

Heavy Duty Systems are recommended for high traffic areas where impacts may be expected, such as construction sites and woodland operation. These tanks may be converted from used product collection and storage to new product storage and dispensing.

Please contact us for more details.

Design Features - Primary Containment:

- 3/16" / 4.8mm Spun Roof
- 1/8" / 3.22mm Spun Floor
- 1/8" / 3.2mm Shell
- Vent Stack Height: 11'3" / 3500mm
- Patented Emergency Vent / Fill-Funnel System

Design Features - Secondary Containment:

- 3/16" / 4.8mm Shell
- 3/16" / 4.8mm Floor
- Upper Pipe Guard: 3" / 75mm Sch. 40 pipe
- Lower Pipe Guard: 3" / 75mm Sch. 40 pipe
- Shell Stiffeners: 3" / 75mm Channel
- Fork Pockets: 4" x 8" / 100mm x 200mm HSS

Dimensions:

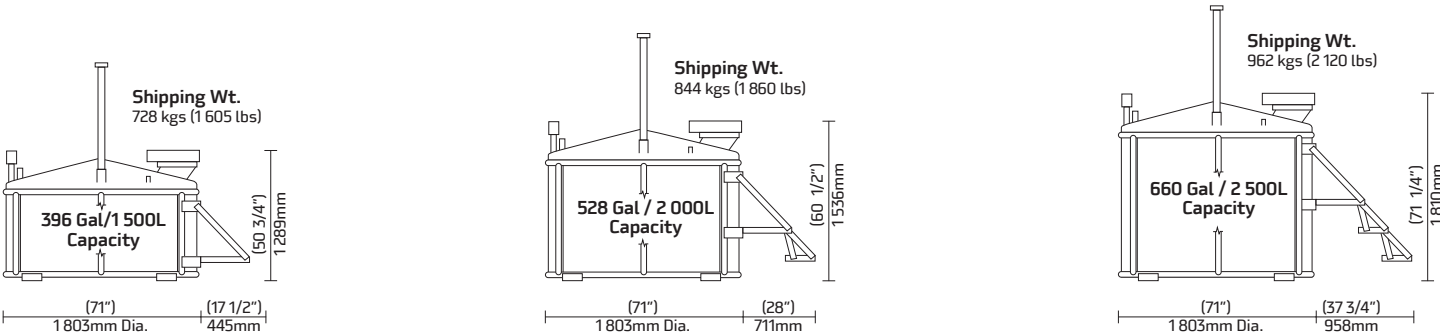

Distributed by:

Inquire for details

